

# SERIES F7363 - JIS 5K

## Cast Iron Gate Valve

Manufactured in accordance to JIS F7400

Flanges as per JIS B2220 - 5K

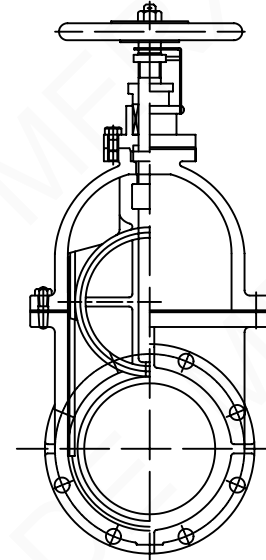
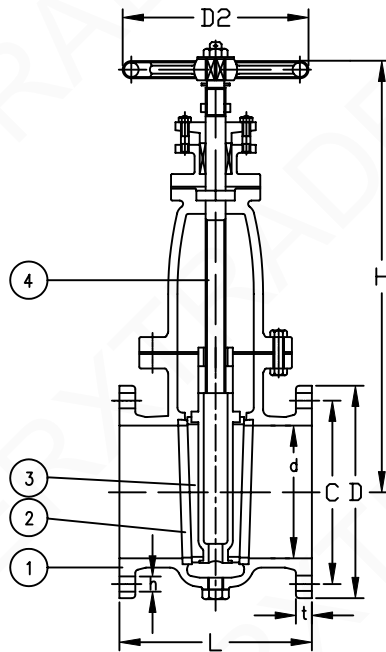

Part Nr.	Material	Code
1 - Body	Cast Iron	FC200
2 - Seat	Stainless steel	SS420
3 - Disc ring	Stainless steel	SS420
4 - Stem	Stainless steel	SS420

Pressure	5 bar
Flanges drilled	JIS 5K

The installation length and flange dimensions are the same as those in the table.  
 The height size (H) can differ slightly per brand.  
 The stainless steel parts are made of SS420 or equal to.

Size	L	D	C	No.	h	t	H	D2	Kg
050	180	130	105	4	15	16	285	125	13.5
065	190	155	130	4	15	18	330	140	19
080	200	180	145	4	19	18	380	160	24.2
100	230	200	165	8	19	20	430	180	35.3
125	250	235	200	8	19	20	495	200	48.1
150	270	265	230	8	19	22	560	224	65.3
200	290	320	280	8	23	24	680	280	103
250	330	385	345	12	23	26	800	355	164
300	370	430	390	12	23	28	920	400	236
350	410	480	435	12	25	30	1000	450	307
400	470	540	495	16	25	30	1100	500	405
450	500	605	555	16	25	30	1400	560	581
500	550	655	605	20	25	32	1500	560	725